

*Mechanical
Hydraulic Hand Pump
Electric Hydraulic*

Docklevelers

EDGE-O-DOCK

27 INCH OR 36 INCH RAMPING LENGTH

STANDARD FEATURES

OPERATING PROCEDURE

(Mechanical E.O.D. series FM)

STEP 1



STEP 2



STEP 3



The **Edge-O-Dock Dockleveler** permanently attaches to the face of your dock, providing immediate use while saving valuable floor space. These levelers never get lost or stolen and they minimize the potential of pinched fingers and toes.

- **Handle Operation**
- **Toe Guards & Grease Zerk Fittings**
- **18" High Bumpers to Service Various Truck Bed Heights**
- **Adjustable Torsion Spring Counterbalance Mechanism (FM Series)**
- **Service Range up to 5" Above and Below Dock Height**
- **Made of High Strength Steel (INX-55, 55,000 psi)**

MECHANICAL • SERIES FM

Molded Bumpers
8"W x 18"H x 2"D

Service Range
Up to 5" Above & Below Dock

High Strength Steel
(INX-55, 55,000 psi)

Self Storing Handle



The **Mechanical Spring Counterbalance Edge-O-Dock** is operated by placing the actuation handle into the hole in the inner lip and pushing down toward the floor. The operator then pulls back up, with Edge-O-Dock lip in the locked position, until it rests on the truck bed. The trailer departs and the lip retracts behind the bumper face automatically. Units come complete with bumpers and handle.

Model Number	Capacity (Pounds)	Ramping Width	Overall Width
FM-0648	6,000	48"	74"
FM-2066	20,000	66"	92"
FM-2072	20,000	72"	98"
FM-2566	25,000	66"	92"
FM-2572	25,000	72"	98"

FM SERIES IN COMBINATION WITH DOCK SEAL REQUIRES 20" MINIMUM PROJECTION

78" Wide Mechanical Units Available

HYDRAULIC HAND PUMP • SERIES PP

The **Hydraulic Hand Pump** system eliminates manual lifting. The hand pump is used to lift the deck and extend the lip. The operator rotates the relief valve allowing the deck to descend down and rest upon the trailer. When the trailer departs the lip drops automatically behind the face of the bumpers. Unit comes complete with bumpers, hand pump with brackets, cylinder, hydraulic line and oil.

Model Number	Capacity (Pounds)	Ramping Width	Overall Width	Ramping Length
PP-2066	20,000	66"	92"	27"
PP-2072	20,000	72"	98"	27"
PP-2566	25,000	66"	92"	27"
PP-2572	25,000	72"	98"	27"
PP-3066	30,000	66"	92"	27"
PP-3072	30,000	72"	98"	27"
PP-1572-36	15,000	72"	98"	36"
PP-2572-36	25,000	72"	98"	36"

78" and 84" Wide Hand Pump Hydraulic Units Available.

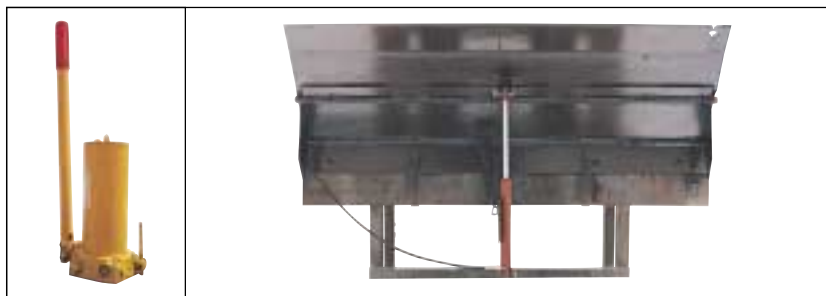

ELECTRIC HYDRAULIC • SERIES PE

The Electric Hydraulic Edge-O-Dock is the easiest to operate. After the truck is backed against the dock, push and hold the control button. The ramp raises and the lip will extend and rest on the truck bed. When the truck departs the lip retracts behind the bumpers automatically. The unit is operated by a 3/4 HP, 110/220 Volt, single phase motor (3 phase available).

Model Number	Capacity (Pounds)	Ramping Width	Overall Width	Ramping Length
PE-2066	20,000	66"	92"	27"
PE-2072	20,000	72"	98"	27"
PE-2566	25,000	66"	92"	27"
PE-2572	25,000	72"	98"	27"
PE-3066	30,000	66"	92"	27"
PE-3072	30,000	72"	98"	27"
PE-1572-36	15,000	72"	98"	36"
PE-2572-36	25,000	72"	98"	36"



Control Panel Mounted Inside Dock



Power Unit is Mounted Under Ramp

CONSULT OWNER'S MANUAL PRIOR TO INSTALLATION

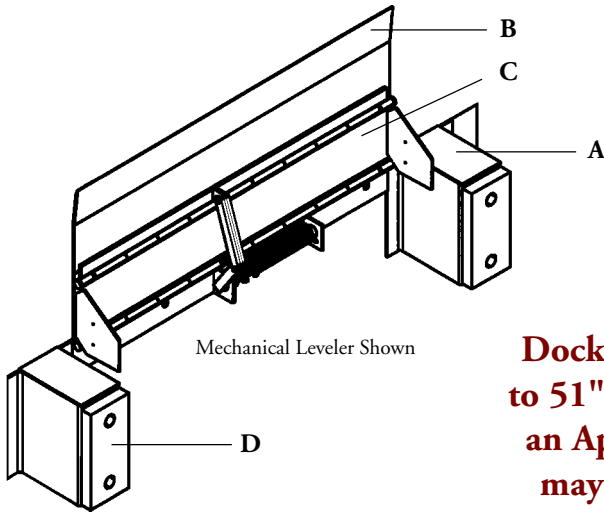

Dock Height of 48" to 51" is Necessary or an Approach Ramp may be Required.

Dimensions for 27" Ramping Length

- A) DOCK BUMPER PROJECTION (Includes Rubber Bumper)
 FM - 15"
 PP - 17-1/2"
 PE - 17-1/2"
- B) OUTER LIP DIMENSION IS 15"
 C) INNER LIP DIMENSION IS 12"
 D) RUBBER BUMPER PADS ARE 8" Wide x 18" High x 2" Deep

Dimensions for 36" Ramping Length

- A) DOCK BUMPER PROJECTION (Includes Rubber Bumper)
 PP - 26-3/4"
 PE - 26-3/4"
- B) OUTER LIP DIMENSION IS 22-5/8"
 C) INNER LIP DIMENSION IS 12"
 D) RUBBER BUMPER PADS ARE 8" Wide x 18" High x 2" Deep

Available Options

- Approach Ramp 96"W x 12"L x 2"H
- Approach Plate 96"W x 12"L x 1/4"T
- Approach Ramp 96"W x 24"L x 4"H
- Curb Edge - 6" Channel x 96"L
- 208/230-460V 3-Phase (Specify at Time of Order)

RECOMMENDED INSTALLATION

When Dock is Under 48 Inches *

Approach Ramp *
 for a 46" to 48" High Dock
 2" Rise
 (model **RAMP-2**)

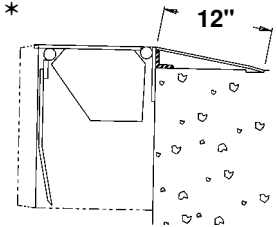

Approach Ramp *
 for a 44" to 46" High Dock
 4" Rise
 (model **RAMP-4**)

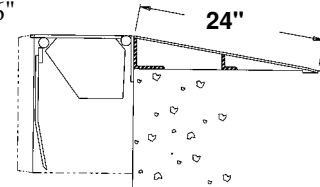

Curb Edge
 for all Edge-O-Docks weld on installation. For new construction (model **CE**)

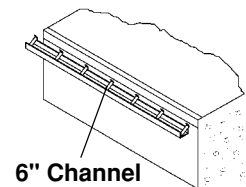

Approach Plate
 for existing docks with no curb edge. Anchor down to dock floor and weld unit on. (model **AP**)

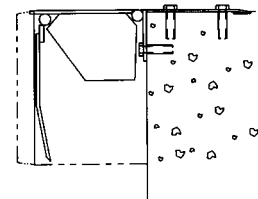

Recommended Dock Height of 48" to 51" Inches

Distributed By: